

We wish you had asked.
The Role of Facilities during
design and construction.

Ken Wertz
MFAA Executive Director

www.massfacilities.com

Why Are We Here ?

- Learn from the past and improve our future.
- Provide you with a different lens.
- Build a better future for our children.

- 963 CMR 2.10(3) School Bldg. Committee



Who's Fault?

- Owner
- Architect
- OPM
- Facilities Industry
- All of the above?

Municipal Relationships:

- Neighbors
- City/Town Officials
- City/Town Departments
- Technology Departments
- Local Volunteer Organizations

Partnerships:

- MSBA
- Utilities / DOER
- CHPS / NEEP
- DOS, DEP, DPH, EPA
- Office of IG & AG
- OSD

We talk with each other!



What are we looking at?



What we are trained to see.



- Designer
 - Bright finishes
 - Day lighting
- Decent lights specified
 - Adequate space
 - Code compliant

What we are trained to see.



- Facilities Manager
 - 20watts for TV
 - Impossible dusting
 - HVAC access?
 - Acoustic nightmare
- Light fixture paper baskets that require different parts

We Know the Bldgs.

- I know there was a fire in the west wing.
- I know which wing takes longer to heat.
- Teacher XYZ 3 is going to be difficult.
- I've crawled in the tunnels.
- I have inventoried parts the builder needs.

Cleaning and Maintenance

- Machinery has to run through classrooms and corridors?
- Where do I charge and fill my auto-scrubber?
- How do I change the lights in my auditorium?
- Staffing structure for proposed building?
- Storage???!!!

Keys to the city



Do you go back and check?



Security

- When is the building going to be used?
FYI: Schools are 7 days a week 12-16 hours per day
- Zones/Petitions for rentals?
- We know where the vandalism usually occurs.
- We know how “they” get on the roof.

Division 9 - Finishes



Division 10

For the Love of Specialties

THE GREAT

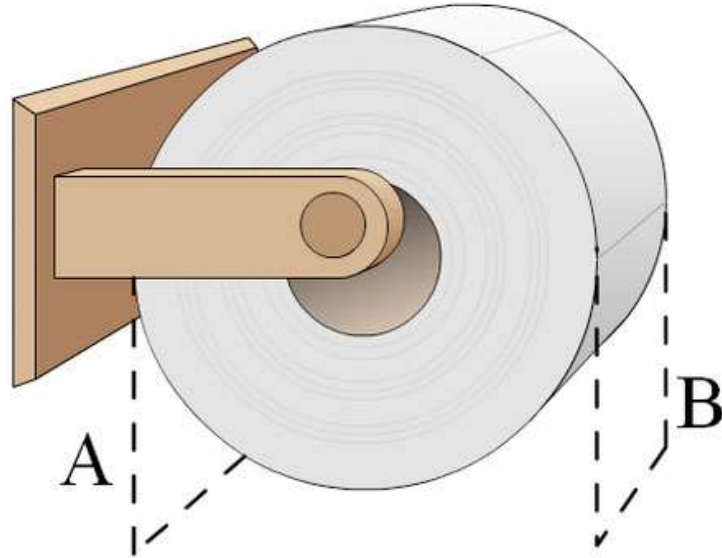

DEBATE

Ask before specifying.



What is wrong with this picture?



Division 22 Plumbing



Division 23 HVAC & Electrical

- Schools are used 7 days/wk. year round
- MEP bldg. Zones/Petitions...rentals!!!
- Wi-Fi the roof?
- Continuity of equipment parts in all buildings.
- Maintenance staff training and operation.
 - What happens when they leave?

Access?



Lighting Controls Are So Important



Division 32 - 33

Earthwork and Exterior

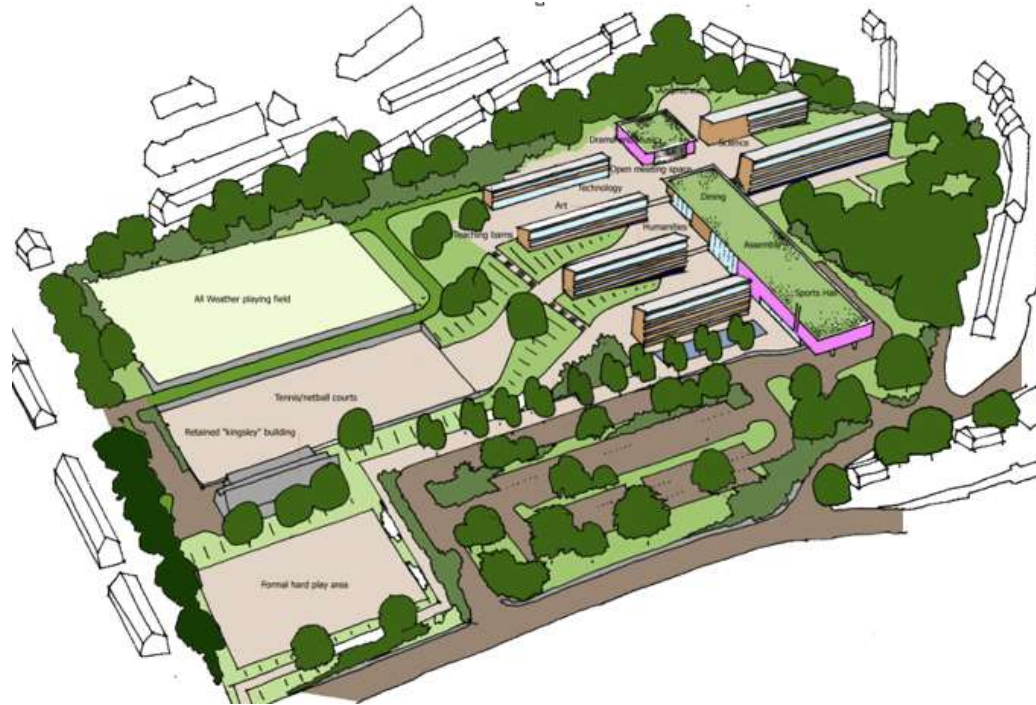

Granite, Concrete, Asphalt?



Design view of snow removal.



Actual view of snow removal.



Project Closeout

- What format will provide the owner with the best transition.
- Electronic format that can be loaded into a work order management system?
- Are systems working properly, not necessarily by design.

Forever

- Sustainable
- Maintainable
- We only have one shot!

MFAA

www.massfacilities.com

Ken Wertz

MFAA Executive Director

exec@massfacilities.com